

# Drayton Lifestyle

**SINGLE CHANNEL**  
Timeswitch

**DUAL CHANNEL**  
Programmer

for heating **OR** hot water

for heating **AND** hot water

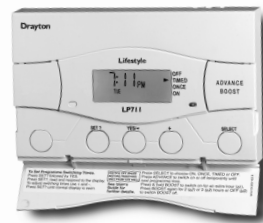

LP111, LP711

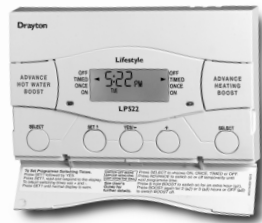

LP112, LP241, LP522, LP722

**SINGLE CHANNEL**

**DUAL CHANNEL**

## Installation Instructions

06490033001 ISSG

Invensys Controls  
Sales: 0845 1305522 / Technical Helpline: 0845 1307722  
Email: customer.care@invensys.com / Web: www.draytoncontrols.co.uk

## INSTALLATION INSTRUCTIONS

**PLEASE NOTE: INSTALLATION MUST ONLY BE CARRIED OUT BY A QUALIFIED ELECTRICIAN OR HEATING ENGINEER. MAKE SURE MAINS INPUT HAS A 3 AMP FUSE.**

### TECHNICAL DATA

LP112, LP241, LP522 & LP722 PROGRAMMERS LP111 & LP711 TIMESWITCHES	
<b>Voltage</b>	230V a.c. +10% - 10% 50Hz
<b>Programmer Rating</b>	2 (1) A 230V a.c. each switch
<b>Timeswitch Rating</b>	2 (1) A 230V a.c.
<b>Ambient temp</b>	Operating: 0° to 45°C Storage: -20°C to 50°C
<b>Without mains power</b>	Display: blank Time: always kept Program times: always preserved
<b>Programming resolution</b>	1 minute
<b>Wiring</b>	Fixed wiring only, to comply with current IEE regulations
<b>Maintenance</b>	Must be maintained by a qualified electrician or heating engineer

Lifestyle Programmers and Timeswitches conform to the essential requirements of these Directives:

2004/108/EC – Electromagnetic compatibility  
2006/95/EC – Low voltage



### BEFORE INSTALLATION

First, make sure the mains supply is switched off!

### PROGRAMMER ONLY

The programmer must be set to the type of system it is to control. The link on the back of the unit has two settings – P and G. P = a fully pumped and controlled system – allowing heating and hot water to be set separately. G = a gravity-fed hot water system – which does not allow independent setting of heating without hot water, though hot water can be controlled alone.

### USING AN EXISTING WALL-PLATE

Loosen the securing screws on the old programmer and unplug it. Check that there's 70mm clearance to the right of the wall-plate, and 25mm above it. Check the chart on the next page to compare terminals and if necessary, change the wiring of the wall-plate to suit. Now plug the Lifestyle unit into the wall-plate and tighten the securing screws.

Check the 3A fuse, and switch on the mains.

### FITTING A NEW WALL-PLATE

The ideal location is 1.4m above floor level, with reasonable lighting, good access, no condensation, no extremes of temperature, and a supporting surface that fully covers the back of the unit.

Position with 70mm clearance to the right, 25mm above, and sufficient room to access the securing screws underneath. Fix, with terminals at the top, either direct to a flat wall using wall plugs and No. 6 x 1" (25mm) woodscrews, or on a flush mounting single conduit box type UA1 (BS4662) using M3.5 x 14 bolts. DO NOT USE A SURFACE MOUNTING BOX.

TIMESWITCH TERMINAL COMPARISONS									
MAKE	MODEL	Earth	Neutral	Live	Common	On	Off	Stop	
Current Models									
Drayton	Tempus 1, 2 (new models)	N	L	1	3	2	4		
Lifestyle	LP111, LP711	N	L	1	3	2	4		
Switchmaster	300	N	L	4	1				
Discontinued/Competitors' Models									
ACL	TC (Towerchron)	2	1	4	7				
Drayton	Tempus 1, 2 (old models)	N	L	1	2	3	4		
Switchmaster	980	N	L	4	1				
Danfoss Randall	TS15, 75 (Mk18)	E	N	L	1	4	2	5/6	
Danfoss Randall	TS715	E	N	L	1	4	2	3	
Danfoss Randall	TS975	E	N	L	5	4	6	2/3	
Danfoss Randall	SET1, SET1E	E	N	L	5	4	6		
Danfoss Randall	SET4	E	N	L	5	4	6		
Danfoss Randall	103, 103E, 103E5, 103E7	4	5	6	3	1	2		
Danfoss Randall	911, 971	E	N	L	5	6	4	2	
Grasslin Towerchron	QE1	E	N	L	2	4	3		
Grasslin Towerchron	T2001, T2001Q	E	N	L	7				
Honeywell	ST 6100A, ST 6100C	N	L	1	4	2			
Honeywell	ST 7000B	N	L	4	3	2			
Horstmann	Centaur SC1, SC7	N	L	4	3	2			
Horstmann	Centaur Plus, C11, C17	N	L	2	4	3			
Horstmann	Emerald 423, Pearl Auto	E	N	L	3	4			
Horstmann	517, Coronel, H11, H17	E	N	L	5	4	6		
Landis & Staefa	RWB3	N	L	4	3				
Landis & Staefa	RWB30, RWB50, 100, 152, 170	N	L	2	4	3			
Landis & Staefa	RWB7	N	L	2	4	3	1		
Potterton Myson	EP4000, 4001, 4002, 5002	E	N	L	5	4	2		
Sangamo	M6	E	4	6	3	1	2		
Smiths	Controller Mk1, Mk2	N	L	3	2				
Smiths	Controller 30	1	2		4/5				
Smiths	Controller 300, 980	N	L	4	1				
Somvic	Select 107	N	L	1	3	2	4		
Somvic	SP20, SP35	N	L	3	5	4	S		
Venner	Vennerele	N	L	LINE	LOAD				

# Drayton Lifestyle

**SINGLE CHANNEL**  
Timeswitch

**DUAL CHANNEL**  
Programmer

for heating **OR** hot water

for heating **AND** hot water

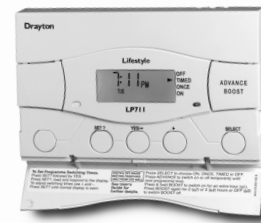

LP111, LP711

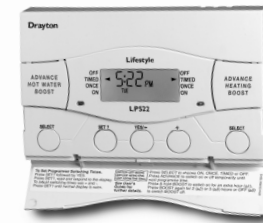

LP112, LP241, LP522, LP722

**SINGLE CHANNEL**

**DUAL CHANNEL**

## User Instructions

06490033001 ISSG

Invensys Controls  
Sales: 0845 1305522 / Technical Helpline: 0845 1307722  
Email: customer.care@invensys.com / Web: www.draytoncontrols.co.uk

## What is a programmer?

...an explanation for householders

Programmers allow you to set 'On' and 'Off' time periods. Some models switch the central heating and domestic hot water on and off at the same time, while others allow the domestic hot water and heating to come on and go off at different times.

Set the 'On' and 'Off' time periods to suit your own lifestyle. On some programmers you must also set whether you want the heating and hot water to run continuously, run under the chosen 'On' and 'Off' heating periods, or be permanently off.

The time on the programmer must be correct. Some types have to be adjusted in spring and autumn at the changes between Greenwich Mean Time and British Summer Time.

You may be able to temporarily adjust the heating programme, for example, 'Override', 'Advance' or 'Boost'. These are explained in the manufacturer's instructions.

The heating will not work if the room thermostat has switched the heating off. And, if you have a hot-water cylinder, the water heating will not work if the cylinder thermostat detects that the hot water has reached the correct temperature.



## User's Instructions TIMESWITCHES

### INTRODUCTION

Lifestyle Timeswitches will automatically control your system by switching it on and off at times that suit you. The red light on the front of the timeswitch shows when it's on.

■ LP111 – a 24hr program, up to 3 heating periods each day, and every day the same.

■ LP711 – a 7-day program, allowing for different timings on each day of the week, up to 3 heating periods each day.

If the engineer hasn't set your timings for you, your timeswitch will work with a standard program that has been set at the factory. If this doesn't suit you, it's very easy to change it – when you've read this introductory section, simply turn to the page for your timeswitch model.

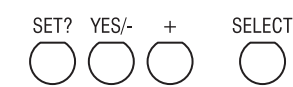

### Remember:

■ Make your changes using the SET?, YES/-, and + buttons.

■ You can't set ON1 as the last timing before midnight, but you can set OFF3 after midnight – providing it's not more than 23 hours and 59 minutes after ON1.

■ You need to set the timings in sequence – i.e. ON1, OFF1, ON2, OFF2, ON3, OFF3. If you get out of sequence, the display will flash a warning.

### INTRODUCTION Cont...

#### SWITCHING

**ON 1** – start of first timed period

**OFF 1** – end of first timed period

**ON 2** – start of second timed period

**OFF 2** – end of second timed period

**ON 3** – start of third timed period

**OFF 3** – final switch-off of the day

If the engineer has set your program and timings – you won't need to do anything else. Just keep this guide in a safe place for future reference.

### DAY-TO-DAY VARIATIONS

Sometimes you might need to change the way you use your system temporarily – perhaps due to an exceptionally cold day. Here's how to do it – without affecting the timings in your program.

#### Switching on and off

On the front of the timeswitch there is an **Advance/Boost** button. It allows you to switch your system either on or off, irrespective of the program. So if the heating is off, and you want warmth now, you can either –

1. Press **Advance** to switch it on (ADV will be displayed), and it will stay on until the end of the next period. Or if the heating is on and you don't need it, press Advance and it will go off until the beginning of the next ON period.

Advance will only operate in TIMED or ONCE modes.

2. Press & Hold **Boost** to switch on for an extra hour (b† and BST will be displayed), then Press again for two (b‡) or three (b‡) hours. To cancel Boost, Press Boost again (b‡). Or if the heating is already on, using Boost will extend the ON time by one, two or three hours.

#### Over-riding the program



At the side of the display there are four operating modes:

**OFF** = continuously off.

**TIMED** = on for up to 3 periods a day.

**ONCE** = on for 1 period a day, from the start of ON1 to the end of OFF3.

**ON** = continuously on.

Use the SELECT button under the flap to change the mode. This won't alter the timings in your program, which you can return to by selecting TIMED.

### THE LP111 24hr ELECTRONIC TIMESWITCH

LP111 – a 24hr program, up to 3 heating periods each day, and every day the same.

Want to leave a timing as it is? Just press SET? and move on to the next one.

If you need to reset your timings to the standard program and start again, press 'SET' and '+' together to go back to the pre-set program.

#### The standard program

Your system will come on for up to 3 heating periods every 24hrs. ON1 starts the first one, OFF1 finishes it, and so on. Notice that ON2 and OFF2 are set to the same time.\* This means your system won't respond, but if you want to activate that middle period or change any other timings – read on.

SWITCHING	STANDARD PROGRAM
<b>ON 1</b> – start of first timed period	6.30am
<b>OFF 1</b> – end of first timed period	8.30am
<b>ON 2</b> – start of second timed period*	12.00pm
<b>OFF 2</b> – end of second timed period*	12.00pm
<b>ON 3</b> – start of third timed period	4.30pm
<b>OFF 3</b> – final switch-off of the day	10.30pm

#### Changing the timings

■ Press the SET? button and you'll see 'SET PROG?'.



■ Press the YES button, and you'll see ON1, the start of your first heating period. Adjust it in 1-minute steps using the – and + buttons. If the – and + buttons are held down, the time changes in 10-minute steps.



■ Press SET?, and you'll see OFF1, the end of your first heating period. Adjust this in the same way, press SET?, then repeat the procedure for ON2, OFF2, ON3 and OFF3.



■ When you press SET? after setting OFF3, the timeswitch will return to normal operation.

### THE LP711 7-DAY ELECTRONIC TIMESWITCH

LP711 – a 7-day program, allowing for different timings on each day of the week, up to 3 heating periods each day.

Want to leave a timing as it is? Just press SET? and move on to the next one.

If you need to reset your timings to the standard program and start again, press 'SET' and '+' together to go back to the pre-set program.

#### The standard program

Your system will come on for up to 3 heating periods every 24hrs. ON1 starts the first one, OFF1 finishes it, and so on. Notice that ON2 and OFF2 are set to the same time.\* This means your system won't respond, but if you want to activate that middle period or change any other timings – read on.

SWITCHING	STANDARD PROGRAM	
	MON-FRI	SAT-SUN
<b>ON 1</b> – start of first timed period	6.30am	7.00am
<b>OFF 1</b> – end of first timed period	8.30am	9.00am
<b>ON 2</b> – start of second timed period*	12.00pm	12.00pm
<b>OFF 2</b> – end of second timed period*	12.00pm	12.00pm
<b>ON 3</b> – start of third timed period	4.30pm	4.00pm
<b>OFF 3</b> – final switch-off of the day	10.30pm	11.00pm

#### Changing the timings

■ Press the SET? button and you'll see 'SET PROG?'.



#### Set all weekdays

First you set the times that are going to be the same for each weekday, then you can select each day individually and make any further adjustments. If you want each day to be quite different, go straight to 'Set each day'.

■ Press the YES button, and the display will ask 'SET MON to FRI PROG?'.



■ Press YES and you'll see ON1, the start of your first heating period. Adjust it in 1-minute steps using the – and + buttons. If the – and + buttons are held down, the time changes in 10-minute steps.



■ Press SET?, and you'll see OFF1, the end of your first heating period. Adjust this in the same way, press SET?, then repeat the procedure for ON2, OFF2, ON3 and OFF3.



#### Set each day

■ If, after you've set OFF3 you want to fine-tune one or more weekdays, press SET? until you find the first day you want to adjust – then go through the procedure, altering any time you wish. Press SET? to move on to the next day. When you've finished, press SET? until you see 'SET SAT SUN PROG?'.



■ If you don't want to alter any individual days, keep pressing SET? until you see 'SET SAT SUN PROG?'.

#### Set weekend



■ Press YES and alter ON1, OFF1, ON2, OFF2, ON3 and OFF3 times in the same way.

#### Set each day

■ If, after you've set OFF3 for both SAT & SUN, you want to fine-tune Saturday or Sunday, press SET? until you find the first day you want to adjust – then go through the procedure, altering any time you wish. Press SET? to move on to the next day. When you press SET? after setting your hot water for Sundays, the programmer will go back to normal operation.



■ If you don't want to alter either day, keep pressing SET? until the programmer goes back to normal operation.

## User's Instructions PROGRAMMERS

If the engineer has set your program and timings – you won't need to do anything else. Just keep this guide in a safe place for future reference.

### INTRODUCTION

Lifestyle programmers will automatically switch your central heating and hot water on and off at times that suit you. Depending on your system, central heating and hot water can either both come on and off at the same time, or work independently. The red light on the front of the programmer shows when each one is on.

There are 4 models in the Lifestyle range:

■ LP112 – a 24hr program, with linked central heating and hot water on for up to 3 heating periods each day, and every day the same.

■ LP241 – a 24hr program, with central heating and hot water working independently for up to 3 heating periods each day, and every day the same.

■ LP522 – a 5/2-day program allowing for different timings at the weekends, with central heating and hot water working independently for up to 3 heating periods each day.

■ LP722 – a 7-day program allowing for different timings on each day of the week, with central heating and hot water working independently for up to 3 heating periods each day.

If the engineer hasn't set your timings for you, your programmer will work with a standard program that has been set at the factory. If this doesn't suit you, it's very easy to change it – when you've read this introductory section, simply go to the section that contains your programmer model.

#### Changing the timings

■ Press the SET? button and you'll see 'SET PROG?'.

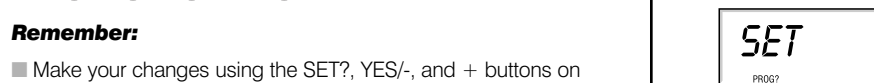

#### Remember:



**THE LP241 24hr ELECTRONIC PROGRAMMER Cont...**

**Set the central heating**

- Press the YES button, and the display will ask 'SET CH PROG?'.



- Press YES and you'll see ON1, the start of your first central heating period. Adjust it in 1-minute steps using the - and + buttons. If the - and + buttons are held down, the time changes in 10-minute steps.



- Press SET?, and you'll see OFF1, the end of your first central heating period. Adjust this in the same way, press SET?, then repeat the procedure for ON2, OFF2, ON3 and OFF3.



**Set the hot water**

- When you press SET? after setting OFF3 for the central heating, the display will ask 'SET HW PROG?'.



- Press YES, then set your times in the same way. Remember, in this mode you can have different times to your central heating if you wish.

- When you press SET? after setting OFF3 for the hot water, the programmer will return to normal operation.

**THE LP522 5/2-DAY ELECTRONIC PROGRAMMER**

LP522 – a 5/2-day program allowing for different timings at the weekends, with central heating and hot water working independently for up to 3 heating periods each day.

If the timings haven't been set for you, then your programmer will still be on the factory-set standard program. This means that central heating and hot water will operate together, with the same timings for weekdays and different ones for the weekend. But it's easy to make changes, and have heating and water working independently – just follow the instructions.

Want to leave a timing as it is? Press SET? and move on to the next one.

If you need to reset your timings to the standard program and start again, press 'SET' and '+' together to go back to the pre-set program.

If you don't press anything for two minutes, the programmer automatically goes back to normal operation.

**The standard program**

Your system will come on for up to 3 heating periods every 24hrs. ON1 starts the first period, OFF1 finishes it, and so on. Notice that ON2 and OFF2 are set to the same time.\* This means your system won't respond, but if you want to activate that middle period, or change any other timings – read on.

SWITCHING	WEEKDAYS		WEEKENDS	
	HW	CH	HW	CH
ON 1 – start of first timed period	6.30am	6.30am	7.00am	7.00am
OFF 1 – end of first timed period	8.30am	8.30am	9.00am	9.00am
ON 2 – start of second timed period*	12.00pm	12.00pm	12.00pm	12.00pm
OFF 2 – end of second timed period*	12.00pm	12.00pm	12.00pm	12.00pm
ON 3 – start of third timed period	4.30pm	4.30pm	4.00pm	4.00pm
OFF 3 – final switch-off of the day	10.30pm	10.30pm	11.00pm	11.00pm

**Changing the timings**

- Press the SET? button and you'll see 'SET PROG?'.



**Set the weekday central heating**

- Press the YES button, and the display will ask 'SET CH MON to FRI PROG?'.



- Press YES and you'll see ON1, the start of your first central heating period. Adjust it in 1-minute steps using the - and + buttons. If the - and + buttons are held down, the time changes in 10-minute steps.



- Press SET?, and you'll see OFF1, the end of your first central heating period. Adjust this in the same way, press SET?, then repeat the procedure for ON2, OFF2, ON3 and OFF3.



**THE LP522 5/2-DAY ELECTRONIC PROGRAMMER Cont...**

**Set weekday hot water**

- When you press SET? after setting OFF3 for the central heating, the display will ask 'SET HW MON to FRI PROG?'.



- Press YES, then set your times in the same way. Remember, in this mode you can have different times to your central heating if you wish.

**Set weekend central heating**

- When you press SET? after OFF3 for the weekday hot water, the display will ask 'SET CH SAT SUN PROG?'. Press YES to confirm, and alter the times in the same way.



**Set weekend hot water**

- When you press SET? after OFF3 for the weekend central heating, the display will ask 'SET HW SAT SUN PROG?'. Press YES, and follow the procedure.

- When you press SET? after OFF3 for HW SAT SUN, the programmer will go back to normal operation.

**THE LP722 7-DAY ELECTRONIC PROGRAMMER**

LP722 – a 7-day program allowing for different timings on each day of the week, with central heating and hot water working independently for up to 3 heating periods each day.

If the timings haven't been set for you, then your programmer will still be on the factory-set standard program. This has central heating and hot water operating together – with the option of having different timings for each day of the week. But it's easy to make changes, and have heating and water working independently – just follow the instructions.

Want to leave a timing as it is? Press SET? and move on to the next one.

If you need to reset your timings to the standard program and start again, press 'SET' and '+' together to go back to the pre-set program.

If you don't press anything for two minutes, the programmer automatically goes back to normal operation.

**The standard program**

Your system will come on for up to 3 heating periods every 24hrs. ON1 starts the first period, OFF1 finishes it, and so on. Notice that ON2 and OFF2 are set to the same time.\* This means your system won't respond, but if you want to activate that middle period, change any other timings – read on.

SWITCHING	WEEKDAYS		WEEKENDS	
	HW	CH	HW	CH
ON 1 – start of first timed period	6.30am	6.30am	7.00am	7.00am
OFF 1 – end of first timed period	8.30am	8.30am	9.00am	9.00am
ON 2 – start of second timed period*	12.00pm	12.00pm	12.00pm	12.00pm
OFF 2 – end of second timed period*	12.00pm	12.00pm	12.00pm	12.00pm
ON 3 – start of third timed period	4.30pm	4.30pm	4.00pm	4.00pm
OFF 3 – final switch-off of the day	10.30pm	10.30pm	11.00pm	11.00pm

**Changing the timings**

- Press the SET? button and you'll see 'SET PROG?'.



**Set all weekdays**

First you set the times that are going to be the same for each weekday, then you can select each day individually and make any further adjustments. If you want each day to be quite different, go straight to 'Set each day.'

- Press the YES button, and the display will ask 'SET MON to FRI PROG?'.



- Press YES and the display will ask 'SET CH MON to FRI PROG?'.



- Press YES, and you'll see ON1, the start of your first central heating period. Adjust it in 1-minute steps using the - and + buttons. If the - and + buttons are held down, the time changes in 10-minute steps.



- Press SET?, and you'll see OFF1, the end of your first central heating period. Adjust this in the same way, press SET?, then repeat the procedure for ON2, OFF2, ON3 and OFF3.



**THE LP722 7-DAY ELECTRONIC PROGRAMMER Cont...**

- When you press SET? after setting OFF3 for the weekday central heating, the display will ask 'SET HW MON to FRI PROG?'.



- Press YES, then set your hot water times in the same way. Remember, in this mode you can have different times to your central heating if you wish.

**Set each day**

If, after you've set OFF3 for your hot water, you want to fine-tune one or more weekdays, press SET? until you find the first day you want to adjust – then go through the procedure, altering any time you wish. Press SET? to move on to the next day. When you've finished, press SET? until you see 'SET SAT SUN PROG?'.



If you don't want to alter any individual days, keep pressing SET? until you see 'SET SAT SUN PROG?'.



**Set weekend**

- Press YES, and alter the central heating and hot water times in the same way.

When you press SET? after OFF3 for HW SAT SUN, the programmer will ask the question TEST? If you want to test your program, see below, otherwise press SET? again. If you don't want to test your program, press SET? again – and you'll be asked the question SET H'DAY? If you want to set a holiday switch off, see page 23, otherwise press SET? again. If you're not going to program in a holiday switch-off, then press SET? again and your programmer will go back to normal operation.

**Test your program**

- This test facility allows you to run through your program to check that the timings are exactly what you want.

Answer YES to TEST? and the display will show Monday and a time just past midnight. Press YES again and hold it down – and the display will start to run through the days of the week, pausing for a few seconds when it reaches an ON or an OFF time. At each pause, the appropriate lights and circuits will come on.

- Release the YES button, and the display will stop running and give you longer to identify a timing.

- Press YES once more, and the display will start running again – and will continue all through the week until you press SET?

- Press SET? and your programmer will go back to normal operation.

Remember - The display shows the strict time sequence, so ON1 for HW could be followed by ON1 for CH, then OFF1 for HW etc. Using this feature you can program your system to

**SET A HOLIDAY SWITCH-OFF**

Applicable to all models.

Using this feature you can program your system to switch off while you're on holiday, then switch back on again in time to have the house warm for your return.

- Press SET? three times and you'll see 'SET H'DAY?'

- Press YES to SET H'DAY? and the display will show '00'.

- Using + and -, set the number of days you want the system to be off.

- Press SET, the display will show 'H'DAY' and the programmer will switch off the system. It will then return to normal operation after the set number of days.

Remember - The programmer counts each pass through midnight as a day. So if on a Saturday morning you don't want the heating on again until Tuesday morning, set for 3 days.

**SETTING THE CLOCK AND DATE**

Applicable to all models.

**SETTING THE CLOCK**

The clock in your programmer has been set at the factory, and automatically accounts for British Summer Time. However, should you need to set the clock, read on.

- Press the SET? button until you see SET CLOCK?.



**Set the hour**

- Press YES once, and then the hour will start to flash. Use the - and + buttons to set the hour, checking for AM and PM.



**SETTING THE CLOCK Cont...**

**Set the minute**

- Press SET?, and the minutes will start to flash. Use the - and + buttons to set the exact time.



- Press SET?, and 'SET DATE?' appears in the display.

If you don't want to change the date press SET? to go back to normal operation. If you do, go on to the next section.

**SETTING THE DATE**

The weekday is automatically calculated from the date, so if the weekday is incorrect you'll need to reset the date.

- Press the SET? button until you see SET DATE?.



**Set the year**

- Press YES and the year will start to flash. Use the - and + buttons to adjust.



**Set the month**

- Press SET? and the month will start to flash. Use the - and + buttons to adjust.



**Set the day**

- Press SET? and the day will start to flash. Use the - and + buttons to adjust.



**Set the Day Light Saving**

- Press SET? and the current DLS status will start to flash for day light saving (British Summer Time). Use the - and + buttons to turn on or off.

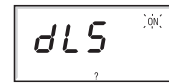

- Press SET? to go back to normal operation.

**USERS NOTES**

**WIRING THE PROGRAMMER Cont...**

**Connection Charts**

**ROOM THERMOSTAT Gravity HW, Pumped CH with Room Stats**

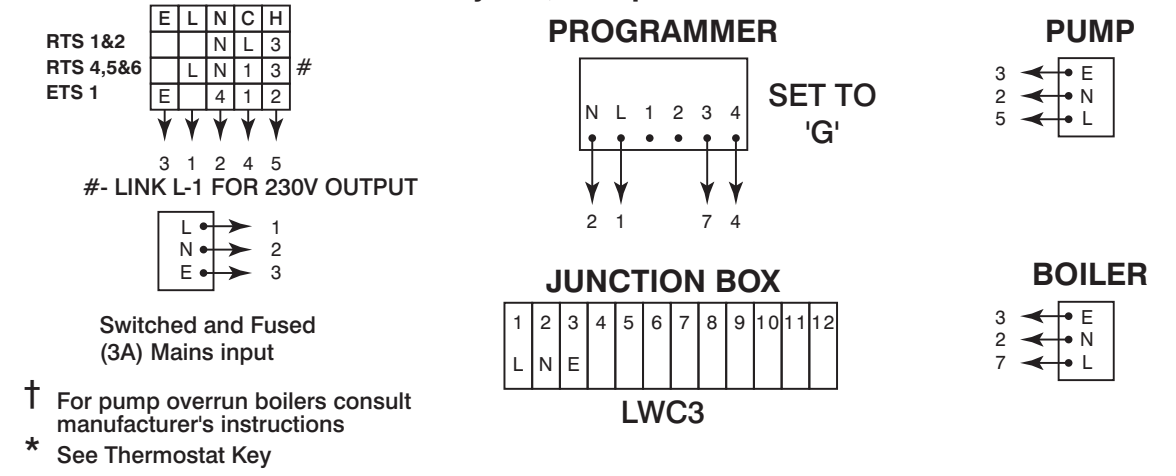

**Mid-Position Valve System**

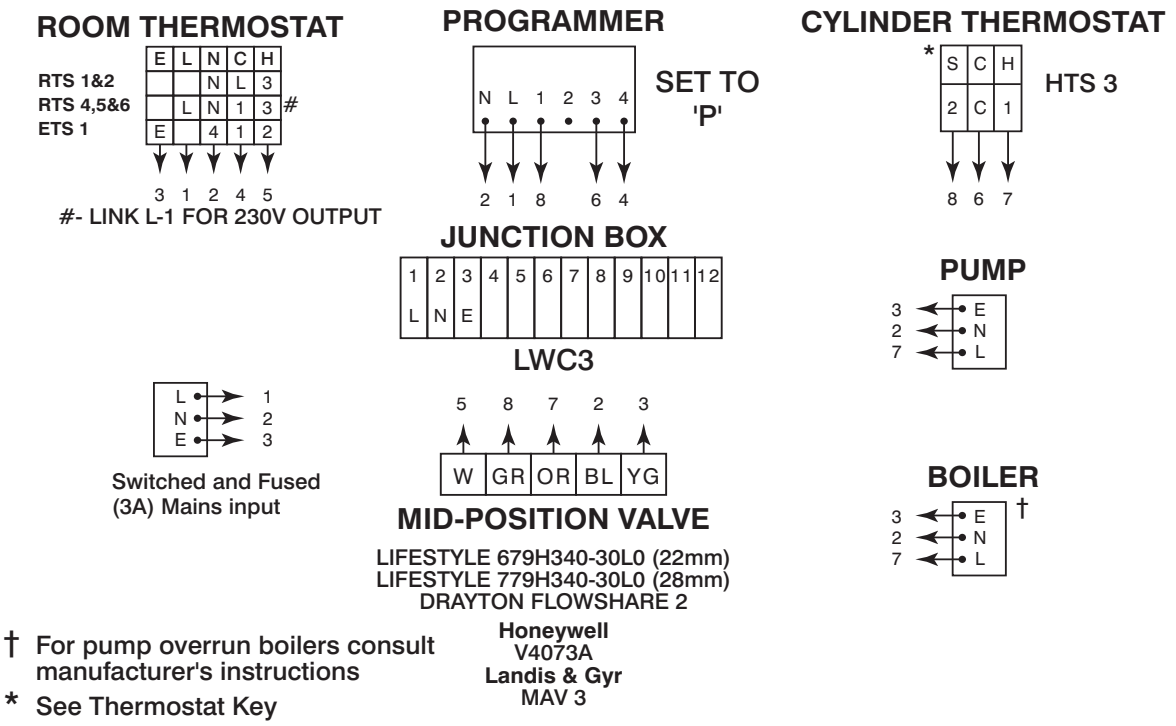

**Spring-Return 2-Valve System**

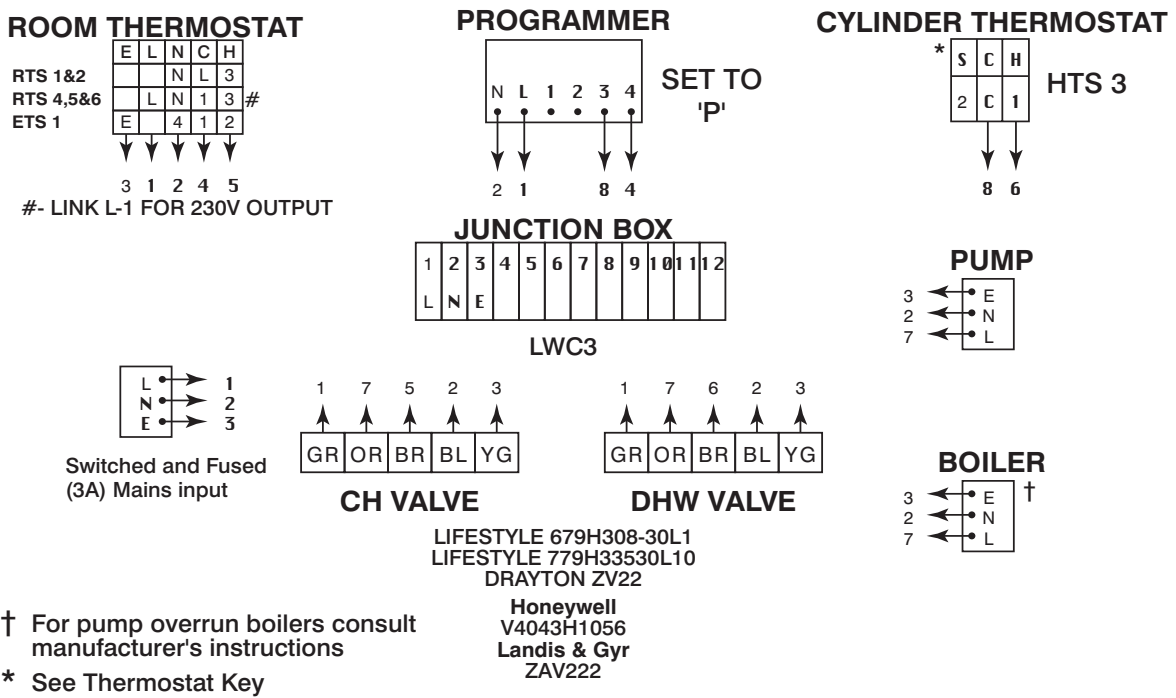

Make the wiring connections, as above, for the appropriate system.

For surface wiring, snap out the cable entry strip on the bottom edge of the wall-plate. Lifestyle units are double-insulated and need no earth connection, but an earthing continuity (loop) terminal is provided for convenience.

After wiring, plug in the unit and tighten the securing screws. Check the mains input has a 3A fuse, and switch on the mains. Then set the timings as shown in the User's Guide.

**ALWAYS SWITCH OFF THE MAINS BEFORE REMOVING THE LIFESTYLE TIMESWITCH/PROGRAMMER - AND NEVER FIT IT TO A LIVE WALL-PLATE!**

**INSTALLERS/ENGINEERS NOTES**

Blank area for installers/engineers notes.

**Invensys Controls**

Sales: 0845 1305522 / Technical Helpline: 0845 1307722  
Email: customer.care@invensys.com / Web: www.draytoncontrols.co.uk

**Invensys Controls**

Sales: 0845 1305522 / Technical Helpline: 0845 1307722  
Email: customer.care@invensys.com / Web: www.draytoncontrols.co.uk